



# SONDEX

## "Semi-Welded" Plate Heat Exchanger SW59

### Recommended applications:

The "Semi-Welded" plate heat exchanger uses laser welded cassettes which are made up of two plates welded together using modern laser welding machines. These cassettes are designed for the refrigeration industry where aggressive products such as ammonia are used. Applications include cooling, heating and heat recovery where one product will be aggressive.

The design pressure is 16 (232PSI) or 25(363PSI) Bar.

**Design principles:**The "Semi-Welded" plate heat exchanger contains a plate pack in which the waved "herringbone" pattern is pressed into each plate.

The products passes through the port holes and into the gap between the plates.

The product which flows **through** the cassettes, is only in contact with the special ring gaskets located in two of the four port holes.

The opposite product flows through the gap sealed by plate gaskets preventing any leaks. However happens when the warmer product transfers energy through the flow plates and delivers it to the colder opposing product without mixing the both products.

The design of the plate and inlet allows for effective and easy CIP (cleaning in place) cleaning of all surfaces in touch with the products.

The "herringbone" pattern ensures turbulent flow within the effective area. Furthermore this pattern brings "metallic" contact between the plates, then optimal differential pressure is achieved.

Duty, type of product, temperatures, pressure drop and the thermal dynamic properties influence the choice of type, size of heat surface and thermal design of the plate pattern.

The plate pack is assembled and pressed together within the frame containing two strong endplates, (head and follower), upper- and lower bars, column and clamping bolts.

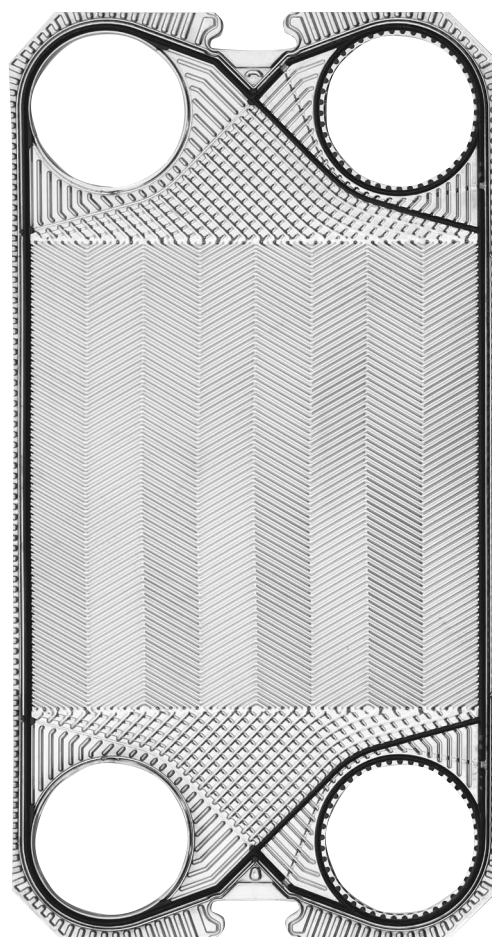

**Plate material:**

Standard is AISI 316 and Titanium.  
When requested also Hastelloy C 276,  
254 SMO or other pressable material.

**Gasket material:**

Plate gaskets are Nitrile, EPDM and Viton.  
Ring gaskets are Nitrile, EPDM,  
Chlorprene and Viton.

**Technical information:**

The painted frame made of St P265GH  
(A36, SA516GR70) and standard colour  
Blue RAL 5010.

Other colours can be supplied.

The frame is constructed for 16(232PSI)  
and 25(363PSI) Bar working pressure.

The clamping bolts are placed around  
the edge of the endplates.

**Construction standard:**

TÜV- Norm A-D "Merkblätter" B5 and  
PED 97/23/EC are followed.  
ASME Code can be supplied.

**Connections:**

DN 200 (8 inches) flanges according to  
all known standards.  
Cladded with AISI 316 or Titanium.

**Accessories:**

Screen plate in Stainless Steel.  
Foundation feet for the frame.  
Spanner / Wrench.  
Insulation jacket.

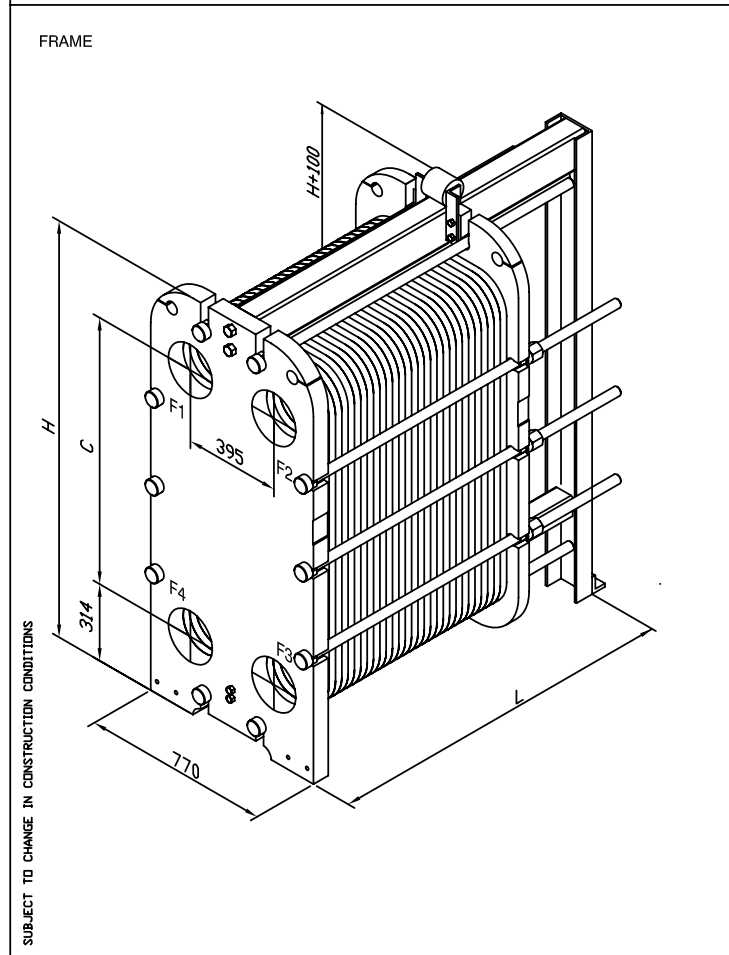
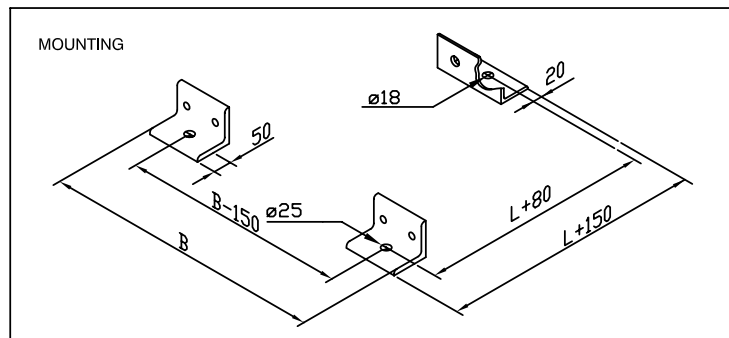

FRAME SIZE	DIMENSION H	DIMENSION C
SW59	1599,5	988
PLATE HEAT EXCHANGER GROUP: SW59 - IS		



SONDEX A/S • JERNET 9 • DK-6000 KOLDING • DENMARK

**SONDEX**

Phone +45 76 30 61 00 • Telefax +45 75 53 89 68 / +45 75 50 50 19 • E-mail: info@sondex.dk