



# SONDEX

## SWE179 Evaporator Plate Heat Exchanger

**The SWE179 Sondex Evaporator** plate heat exchanger is specially developed for evaporation of high concentrated products.

The plate is designed as a semi-welded cassette, with a welded channel for the medium side, and on the evaporation side there is a traditional plate heat exchanger gasket.

The plate is designed in two different plate patterns. For dirty and fibre products, the plate is designed as wide gap plate pattern. For clean products the plate pattern is on the welded side as well as the medium side a herring bone pattern.

The unique plate design ensures an even distribution of the product over the whole plate making optimal rising film evaporation.

The special designed plate pattern ensures a high turbulence of the fluids on both sides, resulting in a high heat transmission coefficient.

This results in a very compact heat exchanger with a small hold-up volume.

### Installation

The large DN700 / 28" connection on the evaporator makes it possible to cover many duties in a single pass solution. This means that all the connections will be on the head of the heat exchanger, which is of big advantage during service work and if the capacity is to be increased.

The plate pattern and inlet area are also designed for CIP cleaning, which makes the service of the plate heat exchanger easy.

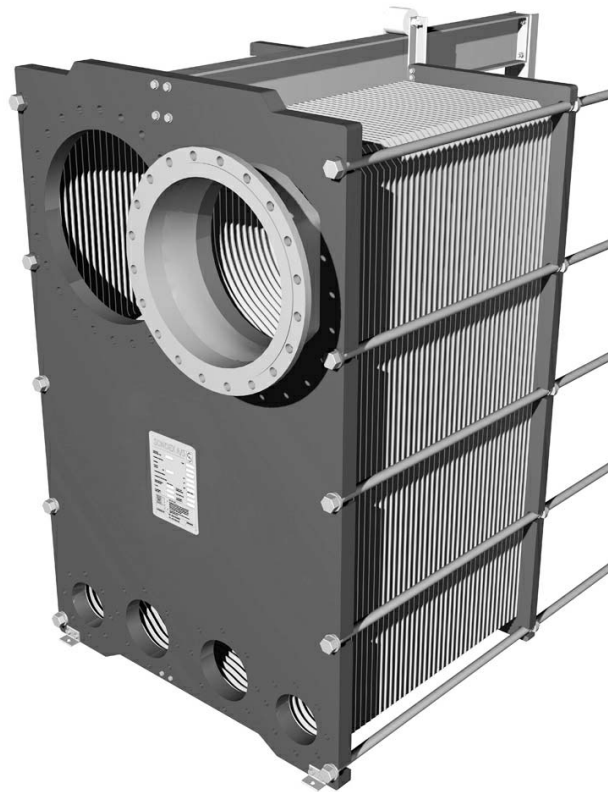

### Plates:

Standard material:

AISI 304 and AISI 316

Not standard: 254 SMO, Hastelloy and other pressable materials.

### Gaskets:

The gasket is the unique "Sonder lock" gasket.

The "Sonder lock" gasket, locks the plates together with strong rubber buttons, so that the plates are strongly guided during the assembling of the plate heat exchanger.

Standard material: Nitrile and EPDM.

Not standard: Viton.

**Technical Information:****Frame:**

Painted frame with placement of clamping bolts on the frame edge.

Standard colour: Blue RAL 5010  
can be made in other colours.

Working pressure:

The frames are designed to the following working pressure  
0,6 MPa /1,0 MPa

**Construction Norm:**

According to TÜV Norm A-D  
"Merkblätter" B5 and PED  
97/23/EC

**Connections:**

Inlet product side

(F4 & F5) DN250 / 10"

Outlet (F1) DN700 / 28"

Flange according to all known standards.

Inlet medium side (F2) DN600 /24".

Outlet (F3 & F6) DN200 / 8".

Flange according to all known standards.

In carbon steel, rubber lined or stainless steel.

**Extra Equipment:**

Screen plate in stainless steel.

Insulation jacket.

Spanner.

Foundation feet for frame.

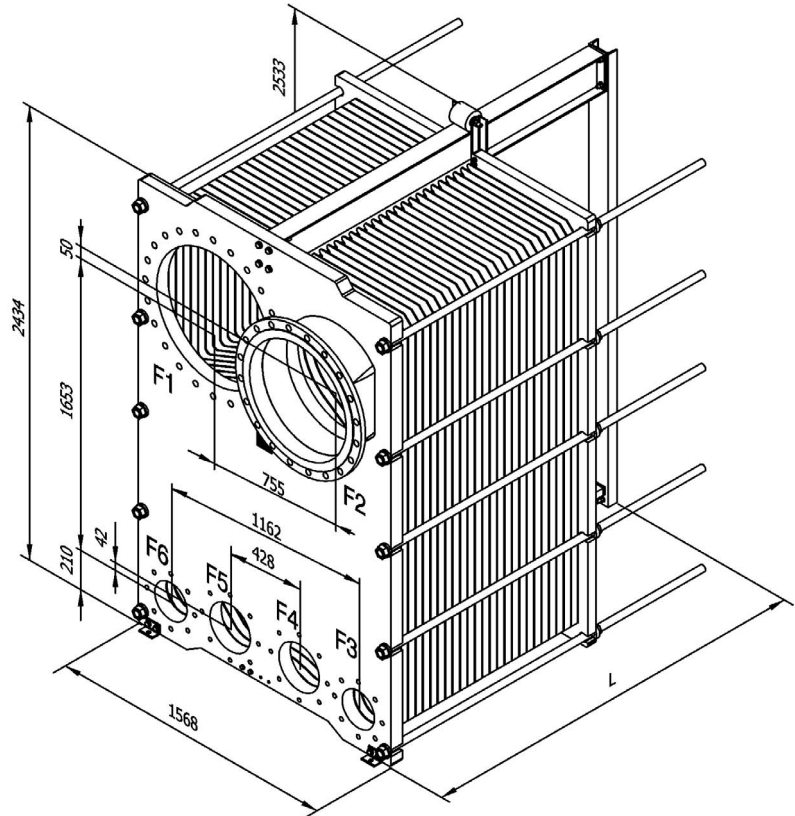

SONDEX A/S • JERNET 9 • DK-6000 KOLDING • DENMARK

**SONDEX**

Phone +45 76 30 61 00 • Telefax +45 75 53 89 68 / +45 75 50 50 19